

TEHNIKOMUNAL

SUVREMENA KOMUNALNA VOZILA

2025

TEHNIKO[®] RAZVOJ - PROIZVODNJA - ODRŽAVANJE



VEĆA
SIGURNOST

KVALITETNIJE
UPRAVLJANJE
VOZILOM



SPRJEČAVANJE
NASTAJANJA OTPADA

PONOVNA
UPORABA

REKILIRANJE
KOMPOSTIRANJE

ENERGETSKA
OPORABA

ODLAGANJE

TEHNIKO[®]



Zelena energija potpuno zadovoljava sve potrebe kompanije TEHNIX



Specijalizirane TEHNIX proizvodne hale za proizvodnju komunalnih vozila



SERVIS

Tomislav Matošić ing. el.
+385 98 388 395
servis@tehnix.com

Milivoj Priher mag. oec.
+385 99 538 2081
ekomunal@tehnix.com

Nikola Madić
+385 98 303 787
tehnix@tehnix.com

TEHNIČKI KONTAKT

Denis Pavlic mag. ing. mech.
+385 99 492 2758
denis.pavlic@tehnix.com

Zoran Kalšan ing. el.
+385 99 232 7828
zoran.kalsan@tehnix.com

Nikola Golub ing. str.
+385 99 324 3590
nikola.golub@tehnix.com



POSLOVNI KONTAKT

Vlado Balent menadžer specijalist

+385 98 241 787

vlado.balent@tehnix.com

Igor Habuš dipl. oec., menadžer

+385 99 346 8825

igor.habus@tehnix.com

Željko Horvat dipl. ing. str., predsjednik uprave

zeljko.horvat@tehnix.com

Već više od tri desetljeća kompanija Tehnix isporučuje inovativne proizvode, opremu i tehnologije za mnoge projekte u Hrvatskoj, Europi i širom svijeta te na taj način obogaćuje društvo, poboljšava kvalitetu života i ima pozitivan utjecaj na okoliš i tehnološke standarde industrije. Osnivač, vlasnik i direktor kompanije Tehnix, g. Đuro Horvat (1943-2023), bio je jedan od najvećih inovatora i izumitelja u Hrvatskoj i ovom dijelu Europe za što je primio stotine priznanja i odličja. Svi proizvodi, oprema i tehnologije kompanije Tehnix vlastiti su izumi i patenti g. Đure Horvata na kojima počiva uspješnost i razvoj kompanije Tehnix u svjetskog lidera na području zaštite okoliša i doprinosu smanjenja klimatskih promjena. Predani smo upravljanju našim poslovanjem na zakonit i odgovoran način, što uključuje poslovanje s partnerima koji poštuju ljudska prava, osiguravaju sigurna i inkluzivna radna mjesta i potiču održivu budućnost. To uključuje borbu protiv klimatskih promjena i zaštitu bioraznolikosti i ekosustava. Slogan kompanije Tehnix je: „Zadovoljan kupac je naš prvi poslovni interes“, što znači da je tržište najbolji partner, ako imate inovativan i kvalitetan te trajno funkcionalan proizvod. Na sljedećim stranicama želimo Vam predstaviti jedan dio Tehnix proizvodnje i razvoja koji se odnose na proizvodnju suvremenih specijalnih komunalnih vozila TEHNIX EKOMUNAL, što uključuje komunalna vozila kapaciteta nadogradnje 5-22 m³. Nadamo se da ćete pronaći potrebne informacije u ovoj brošuri te Vas ujedno pozivamo na zajedničku suradnju u budućnosti.





6 - 7

SUVREMENO KOMUNALNO VOZILO

8 - 22 m³



8

SLIM FIT
najuže vozilo u klasi s tragom guma 2285 mm



9 - 11

EKOMUNAL SAMOPODIZAČ



12 - 13

SUVREMENO KOMUNALNO VOZILO

5 - 9 m³



14 - 15

VELIKA EKOMUNAL VOZILA S KRANOM



16

MALA EKOMUNAL KIPER VOZILA S KRANOM



17

EKOMUNAL DVOKOMORNO VOZILO 30/70



18

SPECIJALNA IZVEDBA VOZILA



19

MODEL: STARO ZA NOVO



20

DETALJI EKOMUNAL NADogradnje



21

DIGITALIZACIJA I SPECIJALIZIRANA OPREMA EKOMUNAL VOZILA



23

BRENDIRANJE I EDUKACIJA

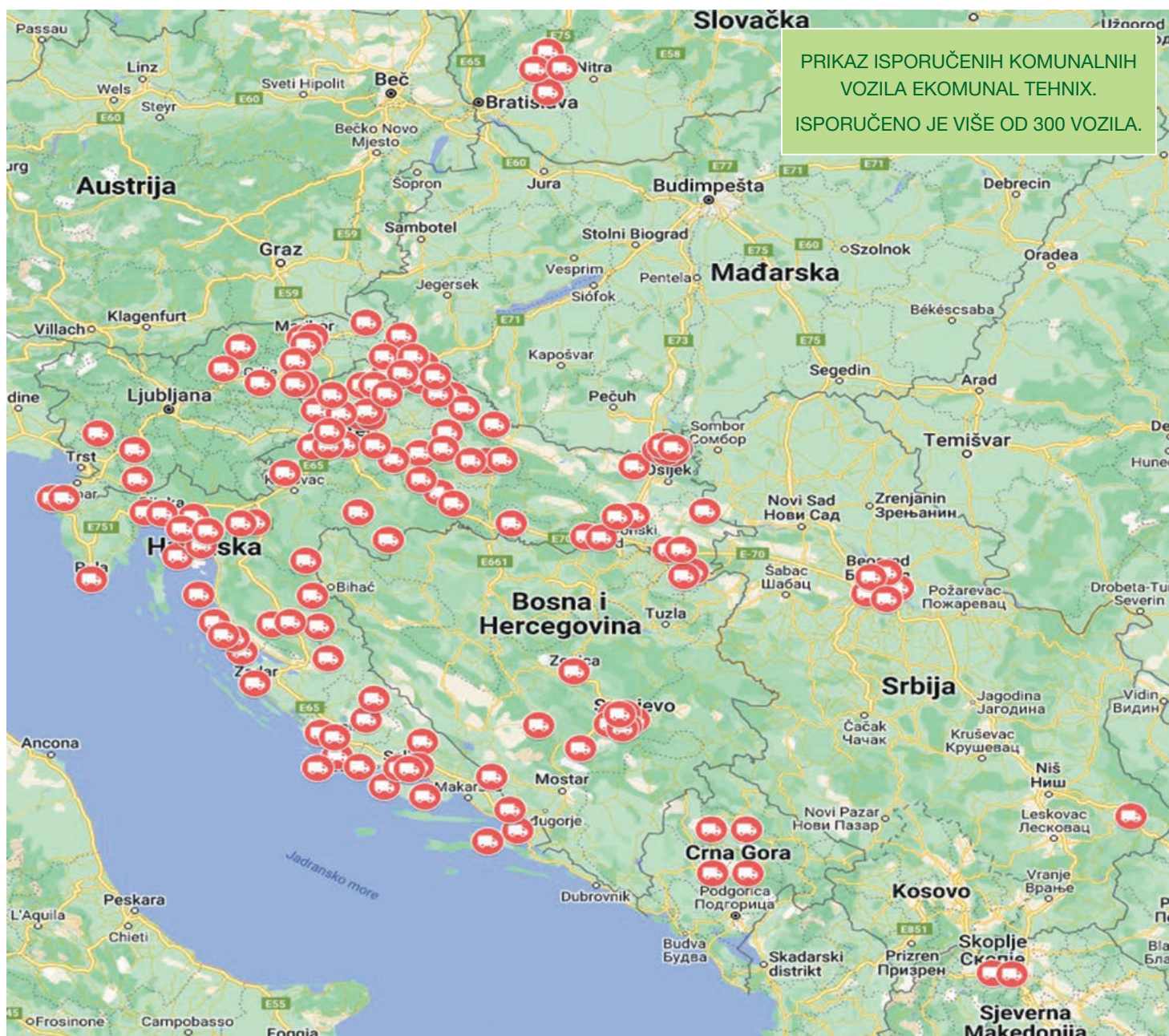

STANDARD DIN - EN 1501-1:2021

U proizvodnji Ekomunal nadogradnje implementirana je sigurnosna europska norma Standard DIN - EN 1501-1:2021. Nekoliko je ključnih točaka sigurnosti prema STANDARDU DIN - EN 1501-1:2021.

- **Radna svjetla** - definirana su radna područja rasvjetnih tijela, bočne strane i stražnja strana
- **Maksimalna brzina** - ograničavanje brzine ovisno o okupiranosti gazišta i transportnog položaja nadogradnje
- **Podizač posuda** - ukoliko su gazišta okupirana iz sigurnosnog razloga podizač nije u funkciji
- **Gazišta operatera** - certificirana ergonomski oblikovana gazišta, normom definirana sigurnost vezana za tri različita položaja gazišta
- **Rukohvati** - pozicija rukohvata definirana prema ljudskoj anatomiji omogućava maksimalnu sigurnost poslužitelja
- **Kamere** - definirano područje pokrivenosti; tri kamere visoke rezolucije i dvije AI kamere za automatski rad podizača



SERVIS I ODRŽAVANJE

Svakodnevno održavanje i redovni servis osiguravaju dugotrajnost i produžuju vijek trajanja.

- **Automatsko podmazivanje** - centralno automatsko podmazivanje nadogradnje u 14 ključnih točaka
- **Servisni otvor na bočnoj strani nadogradnje** - za jednostavniji servisni pristup i svakodnevno održavanje osiguran je bočni otvor na nadogradnji za servis iza potisne ploče
- **Softversko upozorenje** - digitalno praćenje i obavijest o redovnom godišnjem servisu i servisnim akcijama
- **Godišnji servis kompletnog vozila** - u jednom danu paralelni servis podvozja i nadogradnje u Tehnix servisnom centru

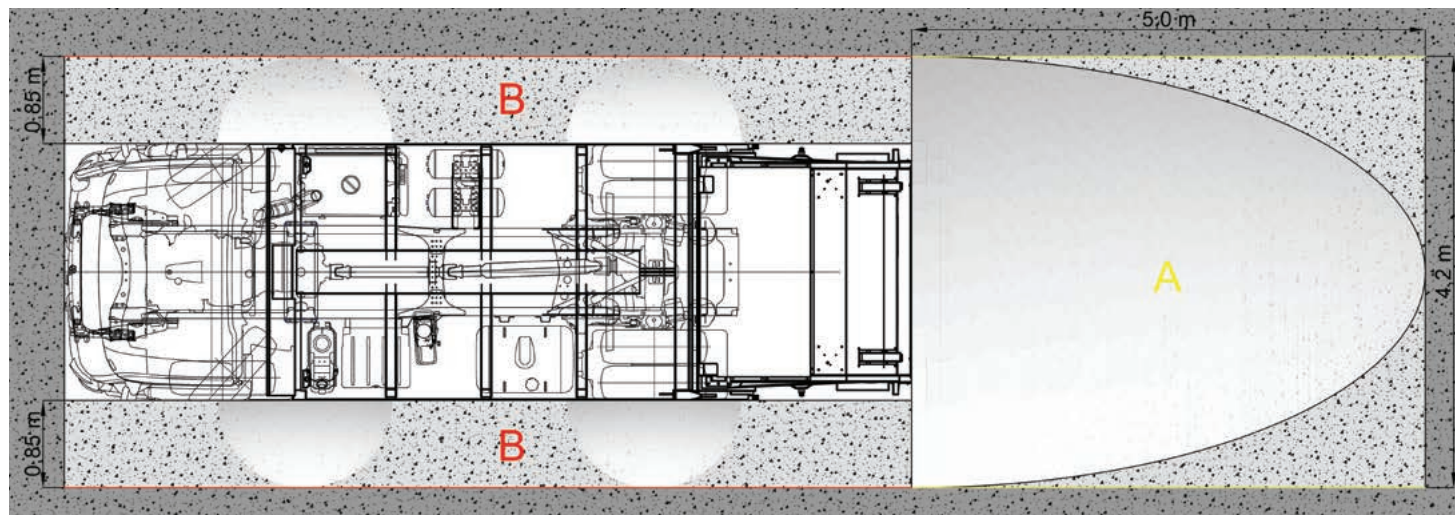



Krstarenje EKOMUNAL 16 m³ vozila



Za polupodzemne kontejnere

18 razloga zašto kupiti komunalno vozilo EKOMUNAL

- Visoka kvaliteta vozila i nadogradnje EKOMUNAL 5 / 6 / 7,5 / 8 / 10 / 12 / 14 / 16 / 18 / 20 / 22 m³
- Dobra cijena, povoljni uvjeti nabave, trajna kvaliteta kompletnog proizvoda
- Osigurani rezervni dijelovi te servis vozila i nadogradnje, jamstvo 12, 24 i 36 mjeseci
- Mala potrošnja goriva, ušteda 30 % uz 20 % veći volumen prihвата otpada
- EURO 6E motor, štedi gorivo uz minimalno ispuštanje emisije CO₂
- Nadogradnja je trajna, skladna, kompaktna tipska konstrukcija
- Svi dijelovi brzo zamjenjivi i visoke kvalitete uz jamstvo trajnosti
- Ugrađen tlačno osjetljiv sustav za maksimalnu sabijenost otpada u prihvatnoj komori
- Sabijanje i izbacivanje otpada pomoću trostupanjskog teleskopskog cilindra
- Video nadzor bočno, iza i ispred vozila, kontrola i rasvjeta utovarnog prostora, sigurnost poslužioca
- Automatsko ograničenje radne brzine i maksimalne brzine vozila
- Rad vozila i nadogradnje vrlo su tihi u radnim uvjetima
- Vršimo obuku vozača i poslužioca EKOMUNAL vozila u poduzeću Tehnix
- Visoki standardi sigurnosti zaštite na radu
- Uz isporuku EKOMUNAL vozila dajemo kompletnu atesnu dokumentaciju i upute za korištenje i održavanje na hrvatskom jeziku
- Posjedujemo zamjensko vozilo u slučaju kvara
- Staro za novo
- Automatizirani podizač



EKOMUNAL volumena 14 m³, 20 500 kg



Pražnjenje 5 i 7 m³ komunalnih kontejnera

SUVREMENO KOMUNALNO VOZILO EKOMUNAL 8 - 22 m³



Pocinčani podizač za kante i kontejnere



Moderan dizajn i individualna vizualizacija



EKOMUNAL 12 podvozje i nadogradnja prema zahtjevu naručitelja



Visoka efikasnost sabijanja i jednostavnost pražnjenja

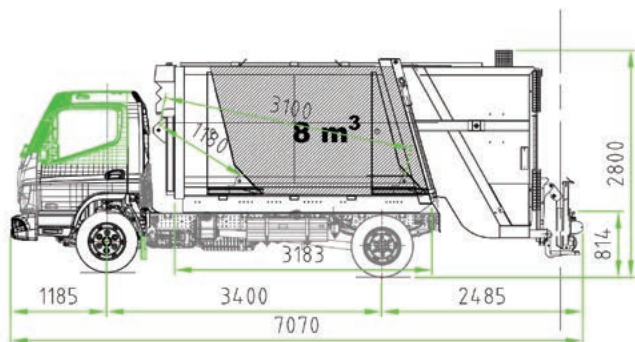

EKOMUNAL 8 m³



EKOMUNAL flota 16 m³ vozila

TIP NADogradnje	TLAČNA KOMORA (m ³)	USIPNA KOMORA (m ³)	DUŽINA (mm)	ŠIRINA (mm)	VISINA (mm)	NAJVEĆA DOPUŠTENA MASA (kg)	BROJ OSOVINA
EKOMUNAL 8	8	1	do 7100	do 2100	do 2900	8 550	2 (4+2)
EKOMUNAL 10	10	1,2	do 7750	do 2500	do 3200	13 500	2 (4+2)
EKOMUNAL 12	12	1,2	do 8250	do 2500	do 3200	16 000	2 (4+2)
EKOMUNAL 14	14	2	do 8500	do 2600	do 3400	18 000	2 (4+2)
EKOMUNAL 16	16	2	do 8800	do 2600	do 3400	18 000	2 (4+2)
EKOMUNAL 18	18	2	do 9500	do 2600	do 3400	26 000	3 (6+2)
EKOMUNAL 20	20	2	do 9900	do 2600	do 3400	26 000	3 (6+2)
EKOMUNAL 21	21	2	do 10 200	do 2600	do 3400	26 000	3 (6+2)
EKOMUNAL 22	22	2	do 10 400	do 2600	do 3400	26 000	3 (6+2)

SLIM FIT - najuže vozilo u klasi s tragom guma 2285 mm



TIP NADOGRADNJE	TLAČNA KOMORA (m ³)	USIPNA KOMORA (m ³)	DUŽINA (mm)	ŠIRINA (mm)	VISINA (mm)	NAJVEĆA DOPUŠTENA MASA (kg)	BROJ OSOVINA
EKOMUNAL 10	10	1,2	do 7750	do 2300	do 3200	13 500	2 (4×2)



Manje dimenzije - veće manevarske mogućnosti



Samopodizač s teleskopskim rukama i dodatnim produžetkom za hidrauličko fiksiranje kontejnera



PTP 5/7

TIP NADOGRADNJE	DUŽINA (mm)	ŠIRINA (mm)	VISINA (mm)	NAJVEĆA DOPUŠTENA MASA (kg)	BROJ OSOVINA
PTP 5/7	do 5700	do 1800	do 2800	7 500	2
PTP 10	do 7000	do 2600	do 3500	13 500	2
PTP 12	do 7500	do 2600	do 3800	18 000	2



PTP 12 - standardna izvedba



Istovar s dodatnim hidrauličkim produžetkom iznad 2 m visine



Standardni istovar preko zahvatne kuke



Stabilizatori i ruke pojedinačno upravljivi za lakšu manipulaciju



TEHNIX samopodizač sa zimskom službom



EKOMUNAL PTP 5/7



Daljinsko radio upravljanje



Dvostruko sigurnosno zaključavanje



Certificirani prihvat prema standardu



Vozila u proizvodnji spremna za isporuku

SUVREMENO KOMUNALNO VOZILO EKOMUNAL 5 - 9 m³



Izvedba s bočnim otvorom i pokrovnom ceradom



EKOMUNAL 7,5



EKOMUNAL 5



EKOMUNAL 5 - individualizirani dizajn prema zahtjevu

TIP NADOGRADNJE	USIPNA KOMORA (m ³)	DUŽINA (mm)	ŠIRINA (mm)	VISINA (mm)	NAJVEĆA DOPUŠTENA MASA (kg)	BROJ OSOVINA
EKOMUNAL 5	5	do 4800	do 1800	do 2800	3500	2
EKOMUNAL 6	6	do 5800	do 2000	do 2800	3500	2
EKOMUNAL 7,5	7	do 5700	do 2000	do 2950	7500	2
EKOMUNAL 9	9	do 6700	do 2200	do 3100	8550	2



100 % električno EKOMUNAL vozilo



Primjer sakupljanja otpada - uske ulice i putevi Dalmacije



Pražnjenje pocinčanih 1100 l komunalnih kontejnera



Rasklopna korpa za prikupljanje u vrećama



Podizanje PVC kanti i kontejnera



Mogućnost pretovara malih u velika vozila pomoću hidrauličnih produžetaka za potpunu preciznost i dodatnu čistoću

VELIKA EKOMUNAL VOZILA S KRANOM



EKOMUNAL 16 m³ s TEHNIX kranom



Vozilo za inozemnog kupca s TEHNIX kranom



Završena montaža u tvornici EKOMUNAL vozila te isporučeno vozilo na zadatku pražnjenja zvonastih kontejnera



Niskopodna verzija kabine s jednom stepenicom; Low entry princip!



ECONIC - niskopodno vozilo s kranom u funkciji

TIP NADOGRADNJE	EKOMUNAL 16 s dizalicom Palfinger	EKOMUNAL 16 s dizalicom Tip Hyva	EKOMUNAL 16 s dizalicom Tip Tehnix
MAKSIMALNI DOHVAT (m)	7,7	7,0	7,7
PODIZNI MOMENT (kNm)	70	62	70
KUT ZAKRETA (°)	316	270	316
RADNI TLAK (bar)	240	250	240
VISINA KOMPLETNOG VOZILA (mm)	do 3950	do 3950	do 3950
TEŽINA DIZALICE (kg)	1100	750	1100
NOSIVOST NA MAKSIMALNOM DOHVATU (kg)	600	600	600

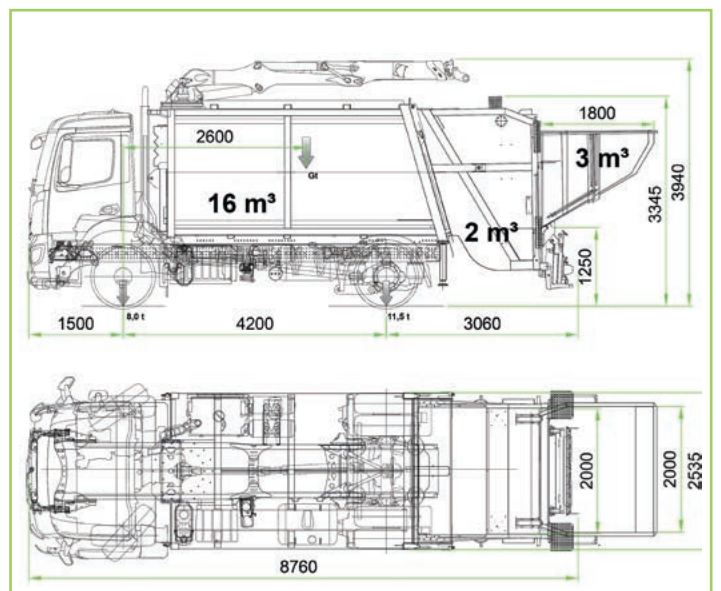

VELIKA EKOMUNAL KIPER VOZILA S KRANOM



Posebni TEHNIX nastavci - montažno-demontažne stranice

TEHNIX grabilica
kapaciteta 0,4 i 0,8 m³



Dvostruko upravljanje kranom - fiksno i radijsko



Trostrani kiper s aluminijском nadogradnjom



Kiper s kranom i harmonika ceradom

MALA EKOMUNAL KIPER VOZILA S KRANOM



EKOMUNAL 7,5 - podizač za kante i kontejnere te kran u funkciji



Specijalno vozilo prema zahtjevu naručitelja



TEHNIX pruža tehničke odgovore na sve zahtjeve u prikupljanju otpada



PALFINGER



EKOMUNAL DVOKOMORNO VOZILO 30/70



Dvokomorno vozilo



Komore 1/3 i 2/3



Primjer rada male daske i lopate



Simultani rad obje komore

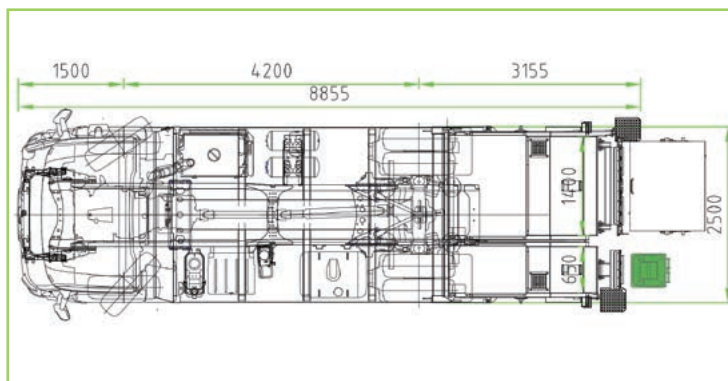

Primjer rada velike daske i lopate

TIP NADOGRADNJE	TLAČNA KOMORA (m ³)	USIPNA KOMORA (m ³)	DUŽINA (mm)	ŠIRINA (mm)	VISINA (mm)	NAJVEĆA DOPUŠTENA MASA (kg)	BROJ OSOVINA
EKOMUNAL 14	10+4	1,2+0,6	do 8500	do 2600	do 3400	18 000	2 (4+2)
EKOMUNAL 16	11+5	1,2+0,6	do 8800	do 2600	do 3400	18 000	2 (4+2)
EKOMUNAL 18	12+6	1,2+0,6	do 9500	do 2600	do 3400	26 000	3 (6+2)
EKOMUNAL 20	13+7	1,2+0,6	do 9900	do 2600	do 3400	26 000	3 (6+2)
EKOMUNAL 22	14+8	1,2+0,6	do 10 400	do 2600	do 3400	26 000	3 (6+2)

SPECIJALNA IZVEDBA VOZILA



Multifunkcionalni trostrani kiper s kranom na šasijsi pogona 4x4 sa zimskom službom



Nadogradnja cisterne za pitku vodu i sve ostale namjene



Nadogradnja kran-navlakač



Kiper s kranom i harmonika ceradom



EKOMUNAL za glomazni otpad - FASSI kran



Servisirano podvozje i nova EKOMUNAL nadogradnja



DETALJI EKOMUNAL NADOGRADNJE



Priručni alat



Vjetrobran



Kutija za alat



Oprema u skladu s cestovnim zakonom



Bočna signalna svjetla



Hidraulika Tehnix



Ergonomski oblikovano stajno mjesto prema ISO 2631



Visokokvalitetni samopodmazujući materijal



Zaštitni kavez rotacijskih svjetala



Sustav za podizanje 5-7 m³ kontejnera



Automatsko podmazivanje kliznih površina u 14 točaka



Upravljački panel



Upravljanje pomoću mobilnog uređaja

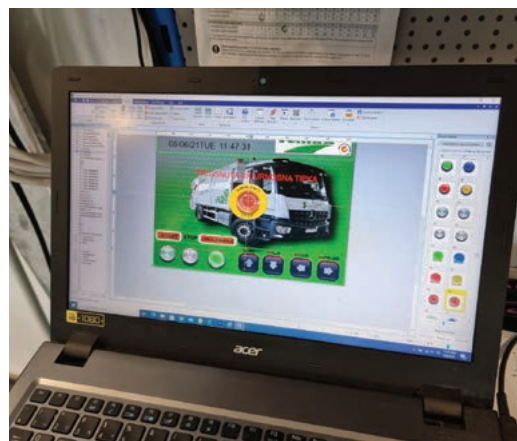

Internet dijagnostika



Sustav videonadzora



Radijsko upravljanje



Upravljački panel



Identifikacijski sustav - RFID i upravljački mehanizam EKOMUNAL nadogradnje



Ugradnja vage na EKOMUNAL vozila

Ispis vaganja



Vlastita proizvodnja kompletne hidraulike

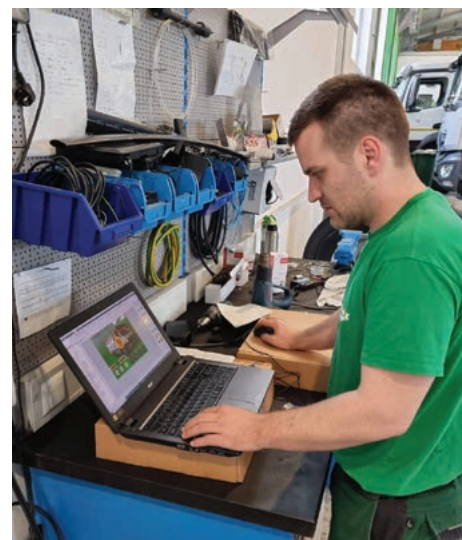

Internet dijagnostika



Montaža TEHNIX nadogradnje

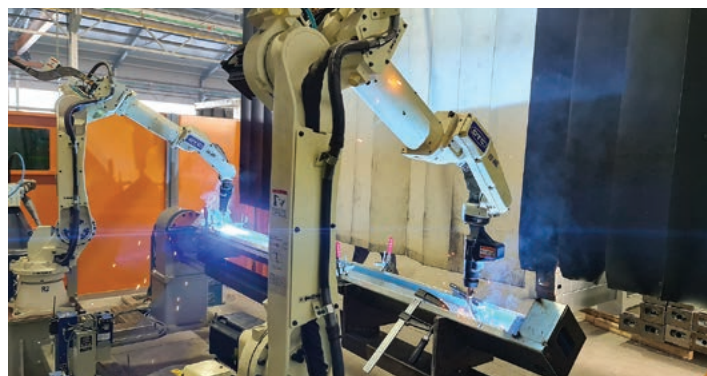

Robotsko lasersko zavarivanje



Strojna obrada



Ugrađeni cilindri tip Tehnix EKOMUNAL



Rezervni dijelovi dostupni odmah



Pocinčana i plastificirana lopata i daska



Izrada naljepnica - brendiranje prema kupcu



Specijalni transport za suvremena vozila



Inženjerski sastanak i razvoj



Edukacija u središnjici TEHNIXA



Obuka na terenu u realnim uvjetima



Sajmovi i konferencije - najveći svjetski sajam ekologije IFAT

EKOINDUSTRIJA TEHNI[®]X

TEHNI[®]X - EKO



SJEDIŠTE KOMPANIJE

Ludbriška 91a / 40320 Donji Kraljevec / HRVATSKA
www.tehnix.com

TEHNI[®]X d.o.o.

centrala: +385 40 650 100
e-mail: tehnix@tehnix.com
OIB: 780 138 46 555

TEHNI[®]X - EKO d.o.o.

centrala: +385 40 650 165
e-mail: info@tehnix-eko.hr
OIB: 67181755846



*Ja sam puzatelj
Tehna*



URED TEHNI[®]X ZAGREB

Krinski trg 14
telefon: +385 1 605 5896
GSM: +385 98 305 795
e-mail: zagreb@tehnix.com

URED TEHNI[®]X SPLIT

Držićeva 7, Solin
telefon: +385 21 244 739
GSM: +385 98 216 794
e-mail: split@tehnix.com

URED TEHNI[®]X SLOVENIJA

Cankarjeva 6e
Maribor, SLOVENIJA
GSM: +386 41 619 828
e-mail: iztok.mirnik@tehnix.com

TEHNI[®]X BEO d.o.o.

Bulevar Peka Dapčevića 55
Beograd, SRBIJA
centrala: +381 11 3978- 775
fax: +381 11 3978- 776
e-mail: beograd@tehnix.com
web: www.tehnixbeo.rs