

# Presjek A-A

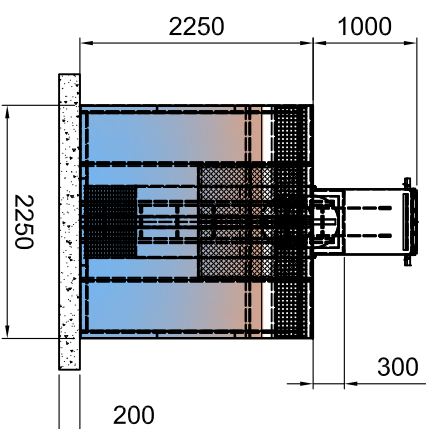

Detalj B  
Mjerilo 1:5

Regulacija kliznih grla vijcima M12x25

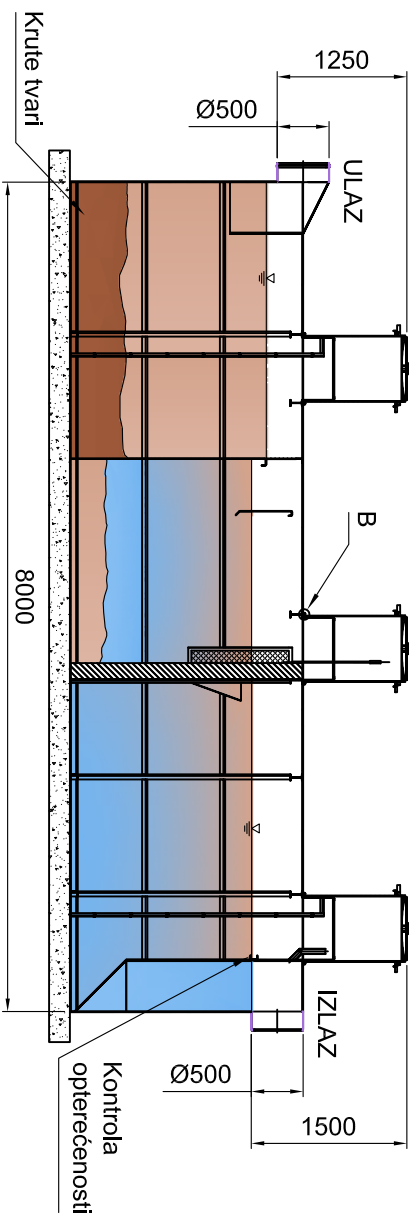
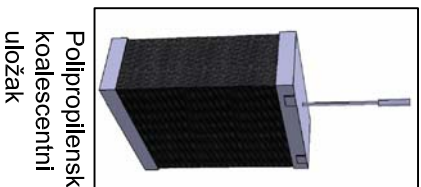
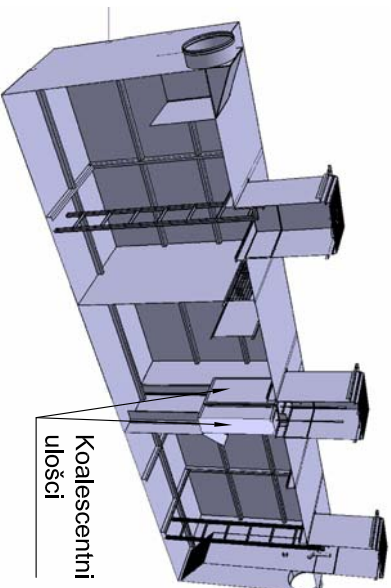
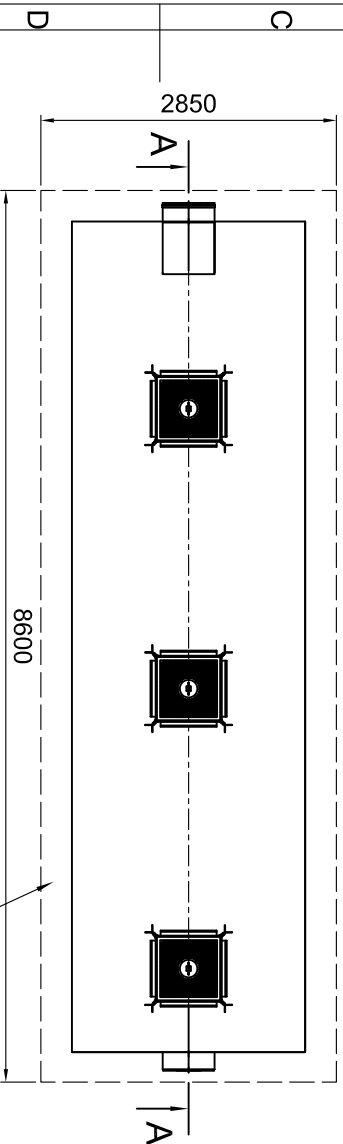

Separatori spadaju u I. klasu separatora prema hrvatskoj normi HRN EN 858 što znači da je količina rezidualnog ulja manja od 5 mg/l

Volumen separatora: 35000 l  
Protok separatora: 150 l/s  
Cijevi: Ø500  
Masa praznog separatora: 6800kg  
Masa punog separatora: 35000kg

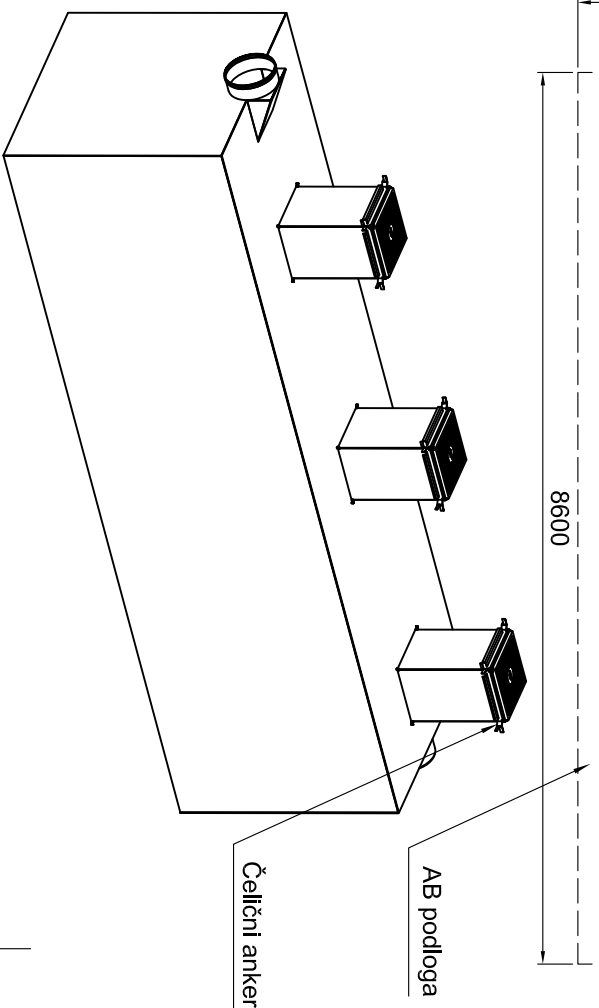

Čelični anker

AB podloga

Površina		Mjerilo	1:50	Pozicija	-	Masa	-
-		-		-		-	
-		-		-		-	

Ime	Datum	Potpis
Čiao		
Prekontl.	Levačić I. dipl.ing.str.	
Odobrio	Horvat D.ming.ing.mech.	
	Horvat Dj. str.teh.sec.	

Separator 35000  
Q=150 lit/sec

**Tehmix**

TX-DK-D-1907-SEP-35000-S1

radbri Promjena Datum Ine Spremljeno TX-DK-D-1907-SEP-35000-S1

5 6 7 8 Page Pg